

UNARCO

RETAIL RACK
ACCESSORIES



Table of Contents

3. Merchandise Dividers

- M-Divider*
- V-Divider*
- Tool Holders*
- Divider Arms*

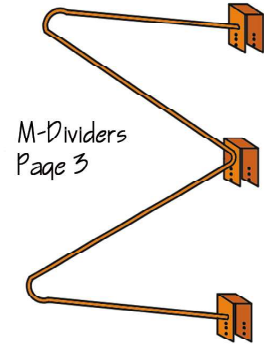

4. Loose Item Display

- Lumber cradles*
- Grid Dividers*
- Tile Shelf Hanging Display*

5. Versa Rack

- Heavy-Duty Beam Mount Posts*
- Thin Profile Adjustable Posts*

6. Versa Rack

- Adjustable L-Rail Shelf Supports*
- Vertical Post Mounting Diagram*

7. Safety Netting & Cable Attachment

- M-Bar Restrainer Bracket*
- Upright Extension Safety Netting Post*
- Upright Mount Cable Bracket*



Versa-Rack
Pages 5-6

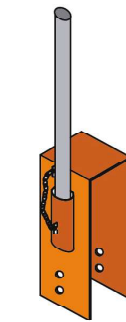

Retainer Brackets
Page 11

8. Safety & Rack Protection

- Vertical Pallet Back Stop*
- Sloped Extender*
- Pallet Back Stop Beam*



Column Protectors
Page 9

Pallet Back Stops
Page 8

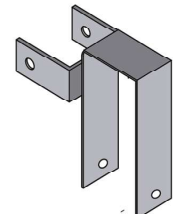

9. Column Protectors

- Structural Column Protectors*
- Anchored Column Protectors*
- Wrap-Around Column Protectors*

10. Fire Safety

- Fire Baffles*
- Wood Spacer Strips*

11. Product Retainer Options

- Door & Window Retainer Beam with Pipe Stops*
- Beam Mount Retainer Brackets*

12. Large Item Display

- Board Rack*
- Wire Reel Holders*
- Upright Mount Spool Holders*

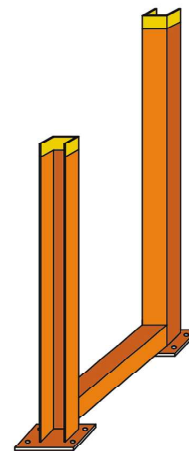

Lumber Cradles
Page 4

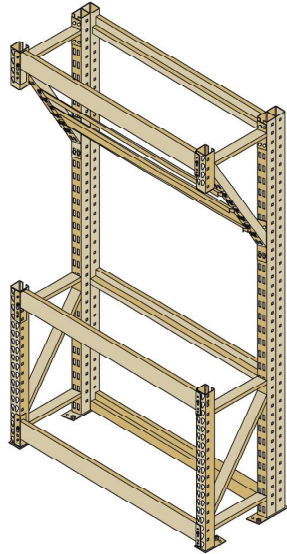

Fan Rack
Page 13

13. Fan Rack

- Angled Uprights*
- Lighting Pod Beam Mounts*

14. Specialty Display

- Rug Table*
- Floor Level Product Protection Hook & Saddle*

15. Pegboard Shelf

- Ultra-Thin Profile Shelving*
- Vertical Mount Pegboard Display*

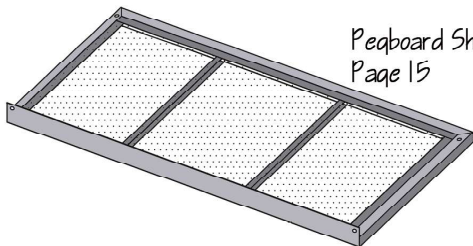

Pegboard Shelves
Page 15

16. Garden Fixtures

- Garden Table Shelves*
- Plant Hanger Garden Displays*

17. Mobile Product Ideas

- Conduit Cart*
- Gravity Flow Rack*

18. DIY TV Mount & Doors

- In-Rack Rolling Doors*
- TV Display Mount*

19. Endcap Shelves

- Cantilevered Beam Mount Shelf*
- Endcap Display Arms*

20. Rack Repair

- Upright Repair Kits*
- Bracing Repair Kits*

21. Retail Signage

- Aisle Signs*
- Beam Covers*
- Rack Mount Junction Box*
- Exit Sign Mount*

22. UNARCO Capabilities

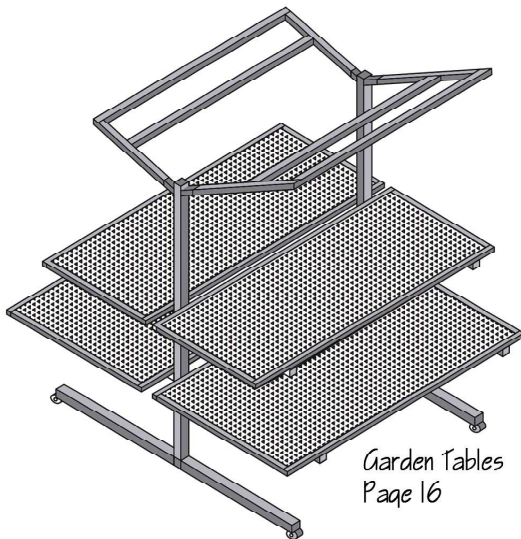

Garden Tables
Page 16

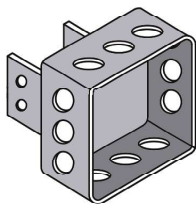

Junction Box
Page 21

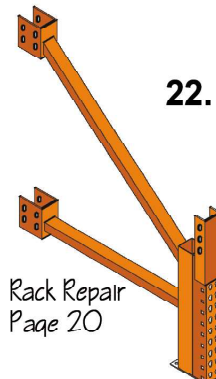

Rack Repair
Page 20

M-DIVIDER & V-DIVIDERS TOOL HOLDERS & DIVIDER ARMS

M-DIVIDER

STRONG ENOUGH TO
HOLD WINDOWS, DOORS
AND LUMBER

1" TUBE: HEAVY DUTY
3/8" WIRE: LIGHT DUTY

AVAILABLE WITH 2 OR 3
BRACKET CONNECTION

CONNECTS TO REAR BEAMS

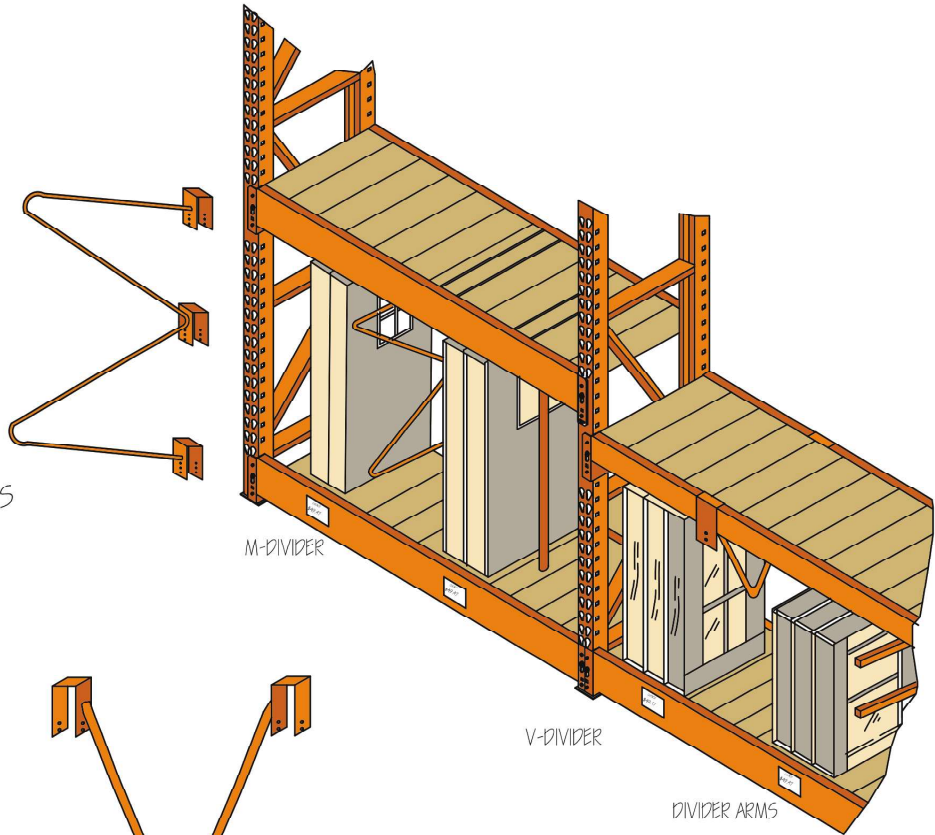

V-DIVIDER

FITS INTO BEAM PAIR OF
UPPER LEVEL SHELF

ORDER TO SHELVING DEPTH

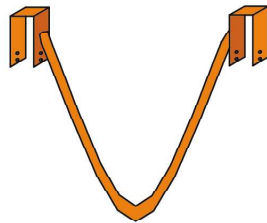

DIVIDER ARMS & TOOL HOLDERS

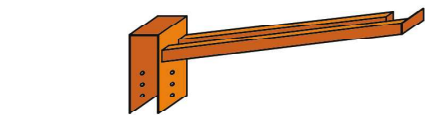

DOUBLE ARM SLOPED TOOL HOLDER

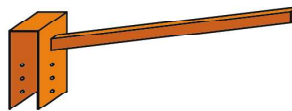

SINGLE ARM DIVIDER ARM

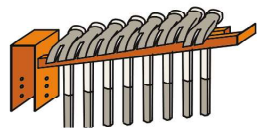

AVAILABLE WITH LABEL HOLDER OR WITHOUT - CUSTOM LENGTHS AVAILABLE

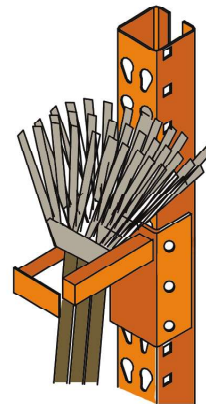

UPRIGHT MOUNT TOOL HOLDER

LOOSE ITEM DISPLAY

LUMBER CRADLES

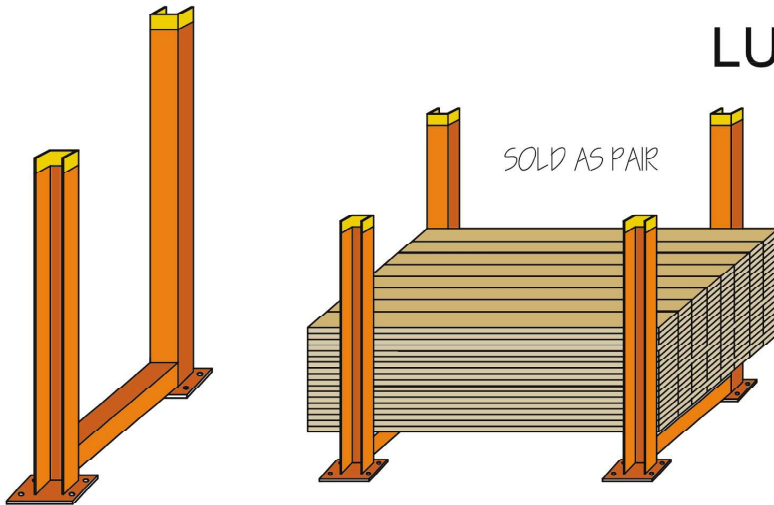

KEEPS ANY LENGTH LUMBER ORGANIZED & OUT OF AISLES

HEAVY-DUTY STRUCTURAL STEEL

AVAILABLE WITH OPTIONAL SIGN MOUNT PLATE

CEILING GRID DIVIDER TRAYS

STORE LONG-LENGTH ITEMS SUCH AS CEILING TILE GRID ON FACE OF BEAM FOR AISLE-SIDE VISIBILITY

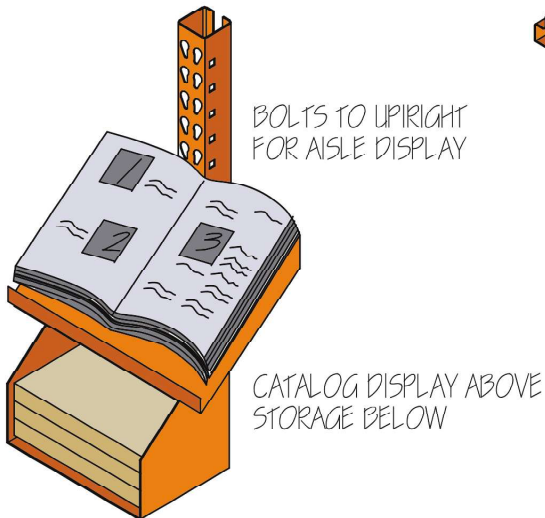
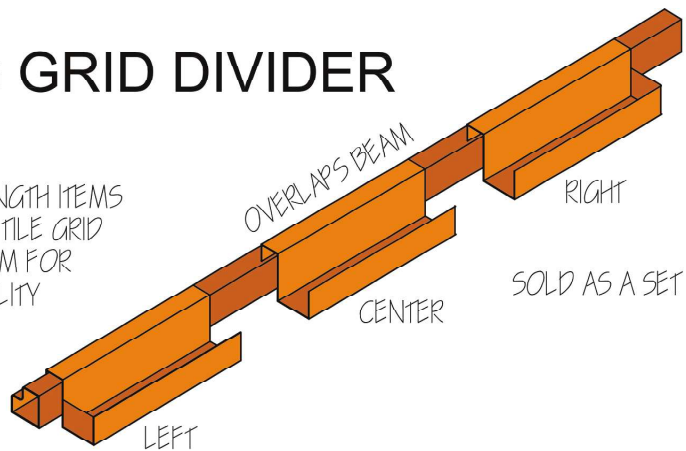

BOLTS TO UPRIGHT FOR AISLE DISPLAY

CATALOG DISPLAY ABOVE STORAGE BELOW

ANGLED CATALOG DISPLAY SHELF

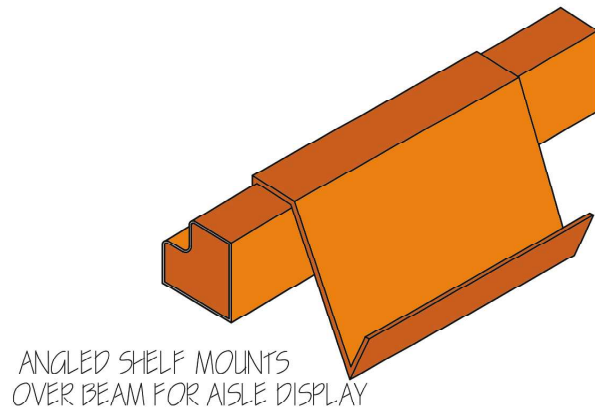

ANGLED SHELF MOUNTS OVER BEAM FOR AISLE DISPLAY

BEAM MOUNT TILE DISPLAY SHELF

VERSA RACK OPTIONS

HEAVY-DUTY POSTS

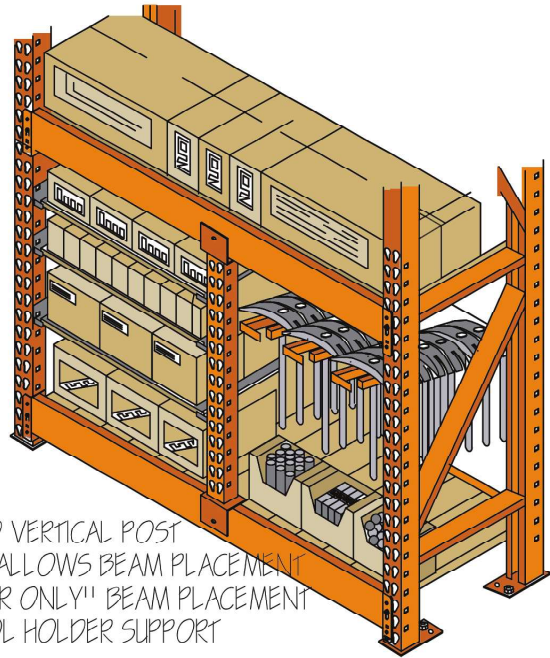
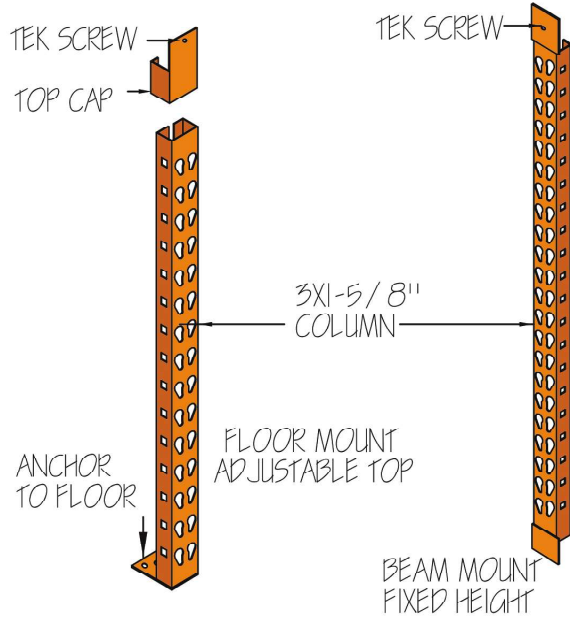

LIGHT-DUTY POSTS

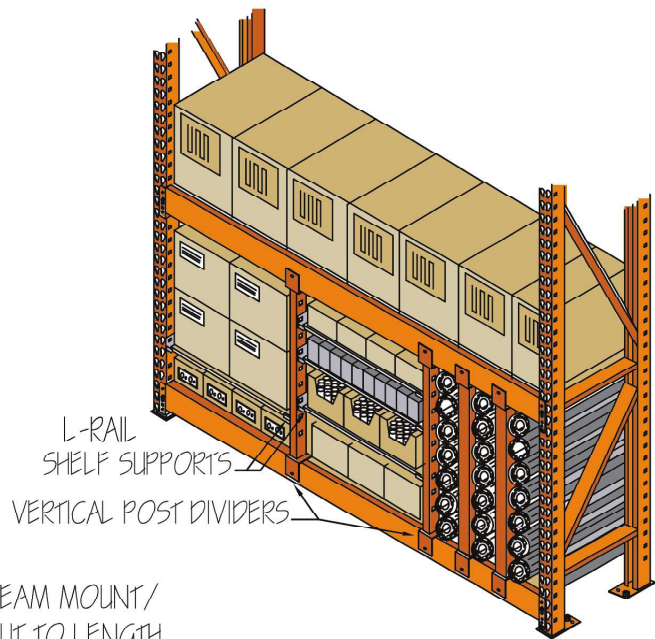
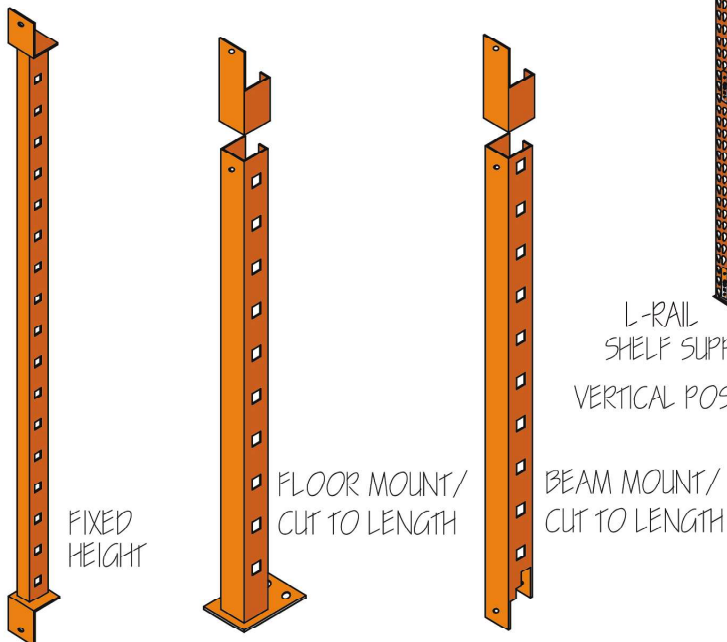

VERSA RACK OPTIONS

ADJUSTABLE L-RAIL SHELF BRACKET

ADJUSTABLE FOR UPRIGHT DEPTHS OF 36" - 48"D

(2) OVERLAPPING RAILS

SLOTTED HOLES FOR EXPANSION FROM 36" - 48" UPRIGHT DEPTH
HARDWARE INCLUDED

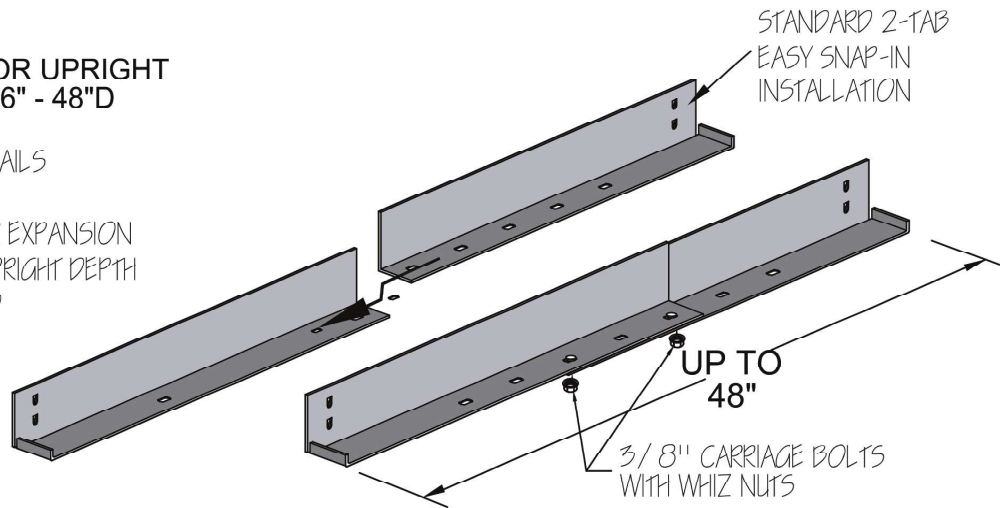

MULTI-HEIGHT VERTICAL POST WITH BRACKETS

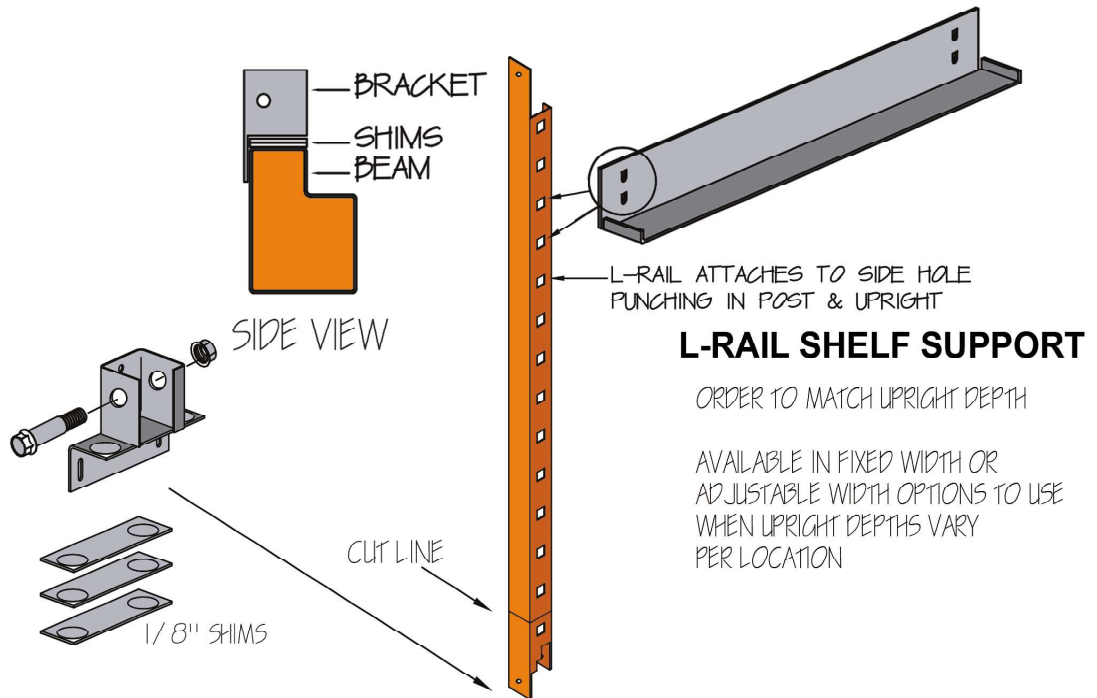

SAFETY & RACK PROTECTION NETTING & CABLE ATTACHMENT

M-BAR RESTRAINER BRACKET

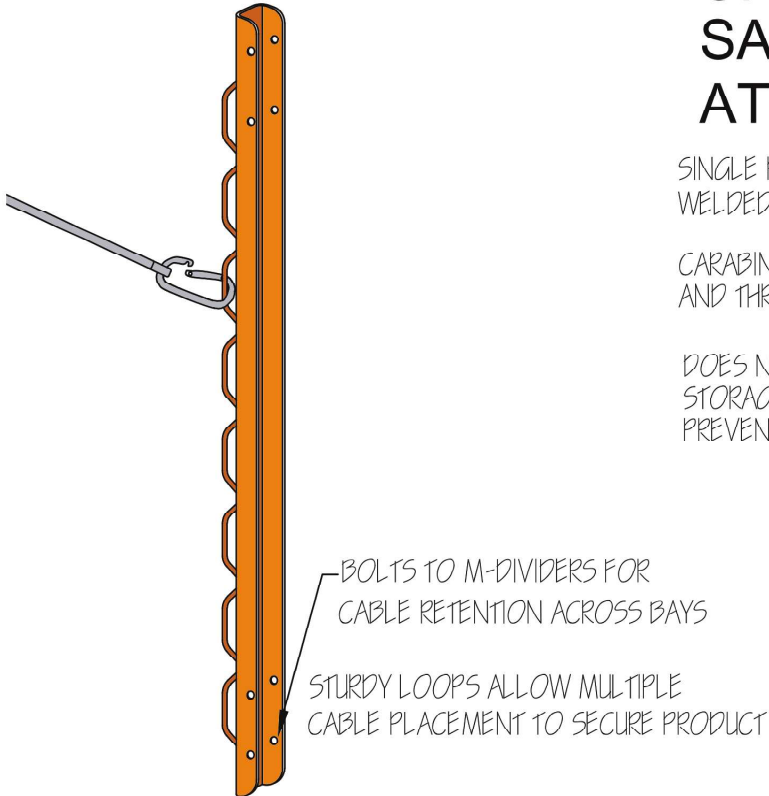

UPRIGHT EXTENSION SAFETY NETTING ATTACHMENT POST

SINGLE POST EXTENSION WITH
WELDED BRACKET

CARABINER ATTACHES TO POST
AND THROUGH NETTING

DOES NOT ALLOW
STORAGE ABOVE TO
PREVENT OVERLOADING

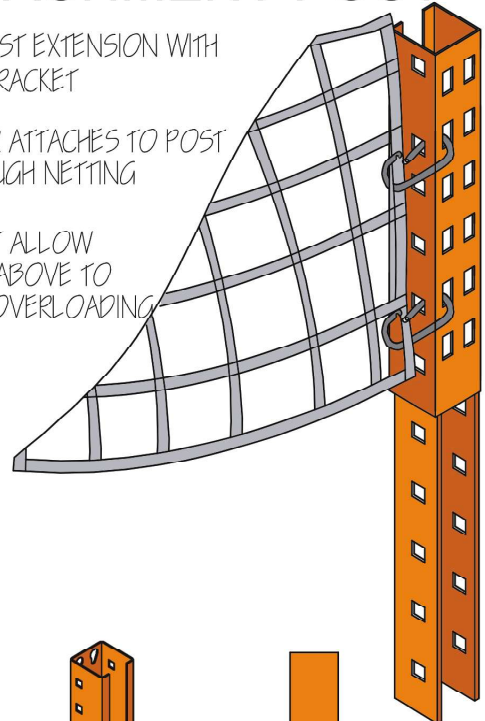

UPRIGHT MOUNT CABLE ATTACHMENT BRACKET

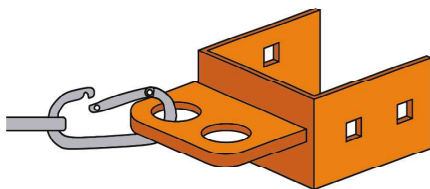

BOLTS TO UPRIGHT FOR EASY
SAFETY CABLE AND
CARABINER ATTACHMENT

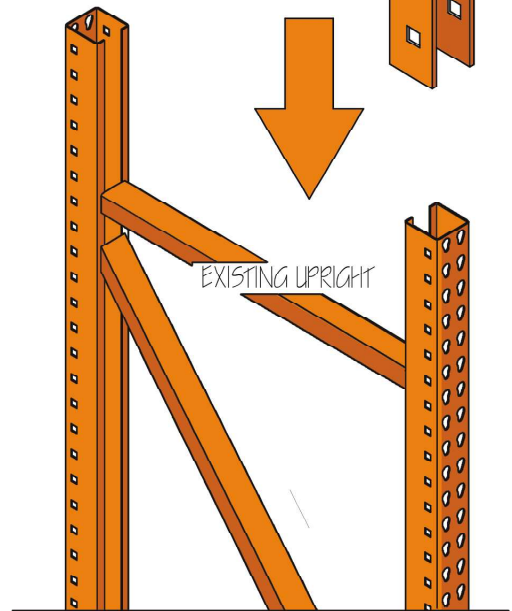

SAFETY & RACK PROTECTION PALLET FALL PROTECTION

PALLET BACKSTOP SAFETY COLUMN

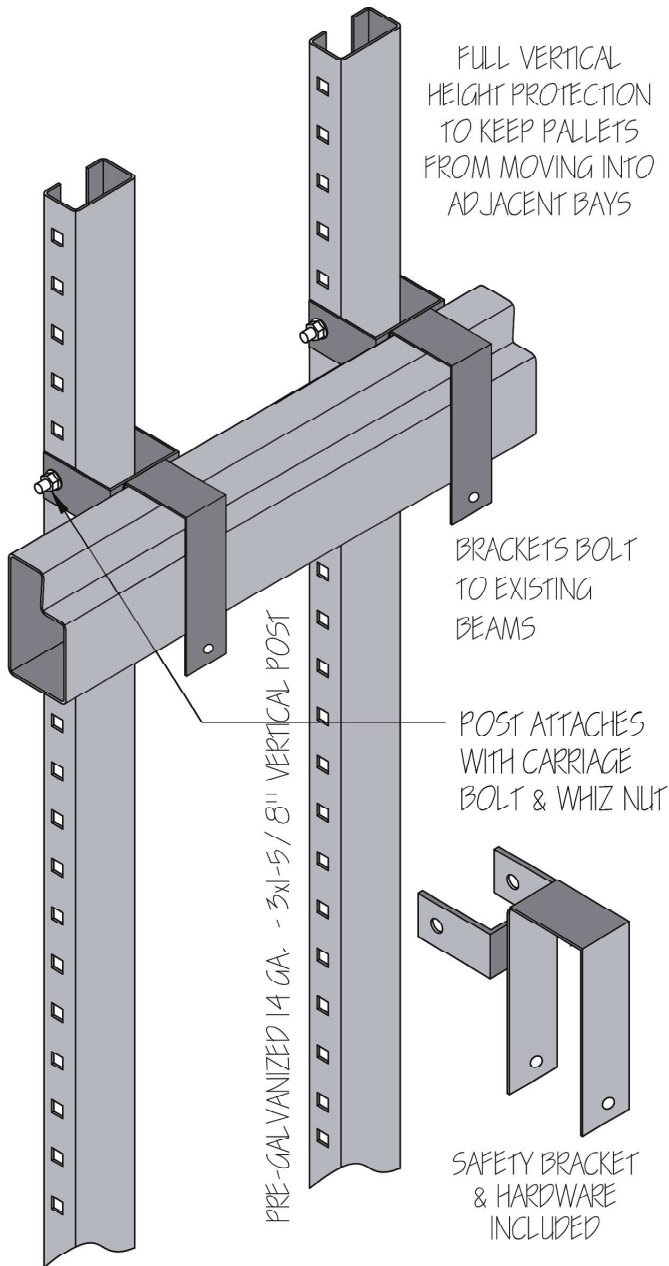

SLOPED EXTENDER

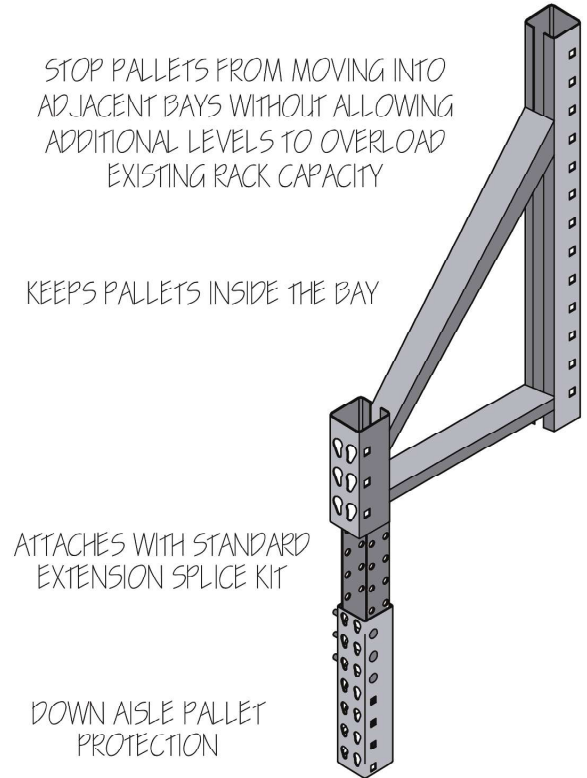

PALLET BACKSTOP FLUE SPACER BEAM

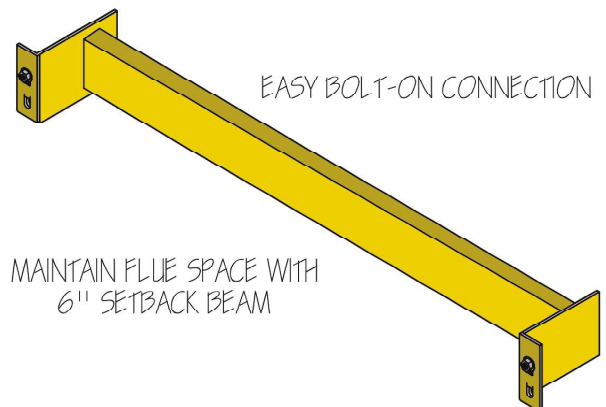

SAFETY & RACK PROTECTION

UPRIGHT PROTECTION

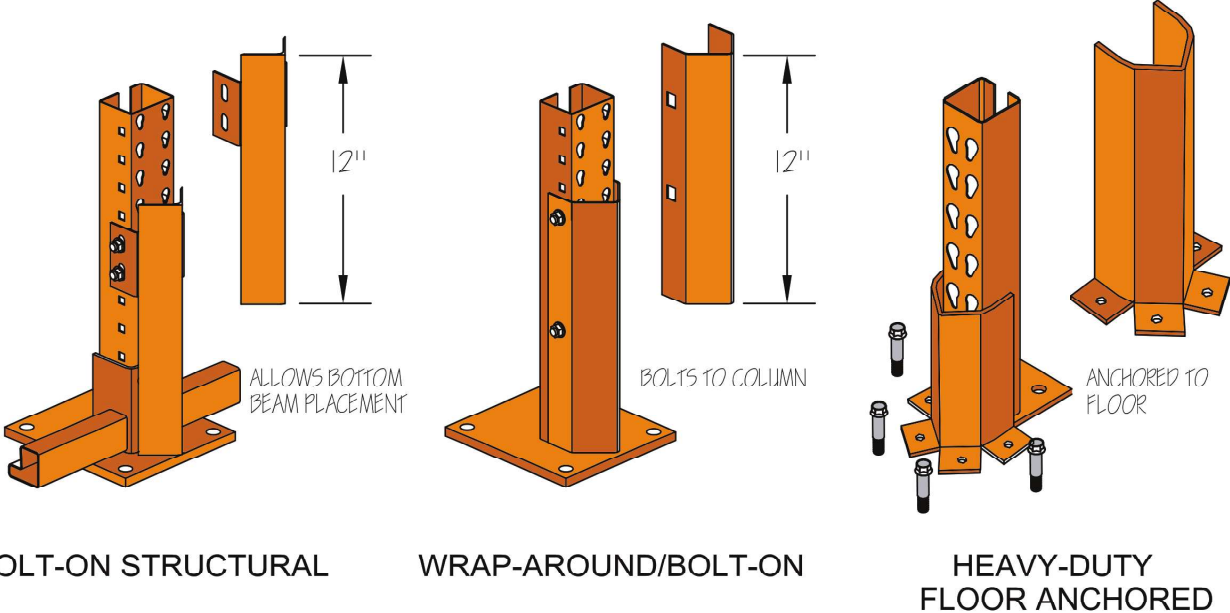

END OF AISLE GUARD

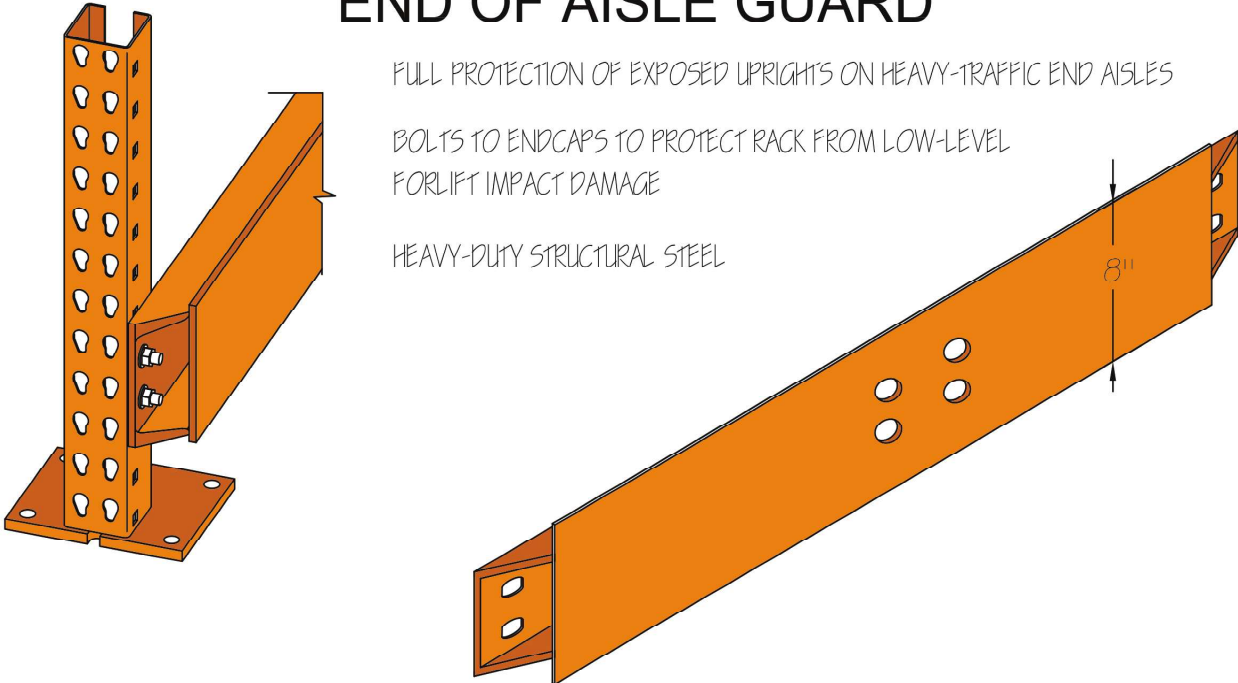

FIRE SAFETY

FIRE Baffles

ADD IN-BAY FIRE PROTECTION EASILY TO HELP WITH LOCAL FIRE CODE SAFETY INVOLVING HAZARDOUS MATERIALS

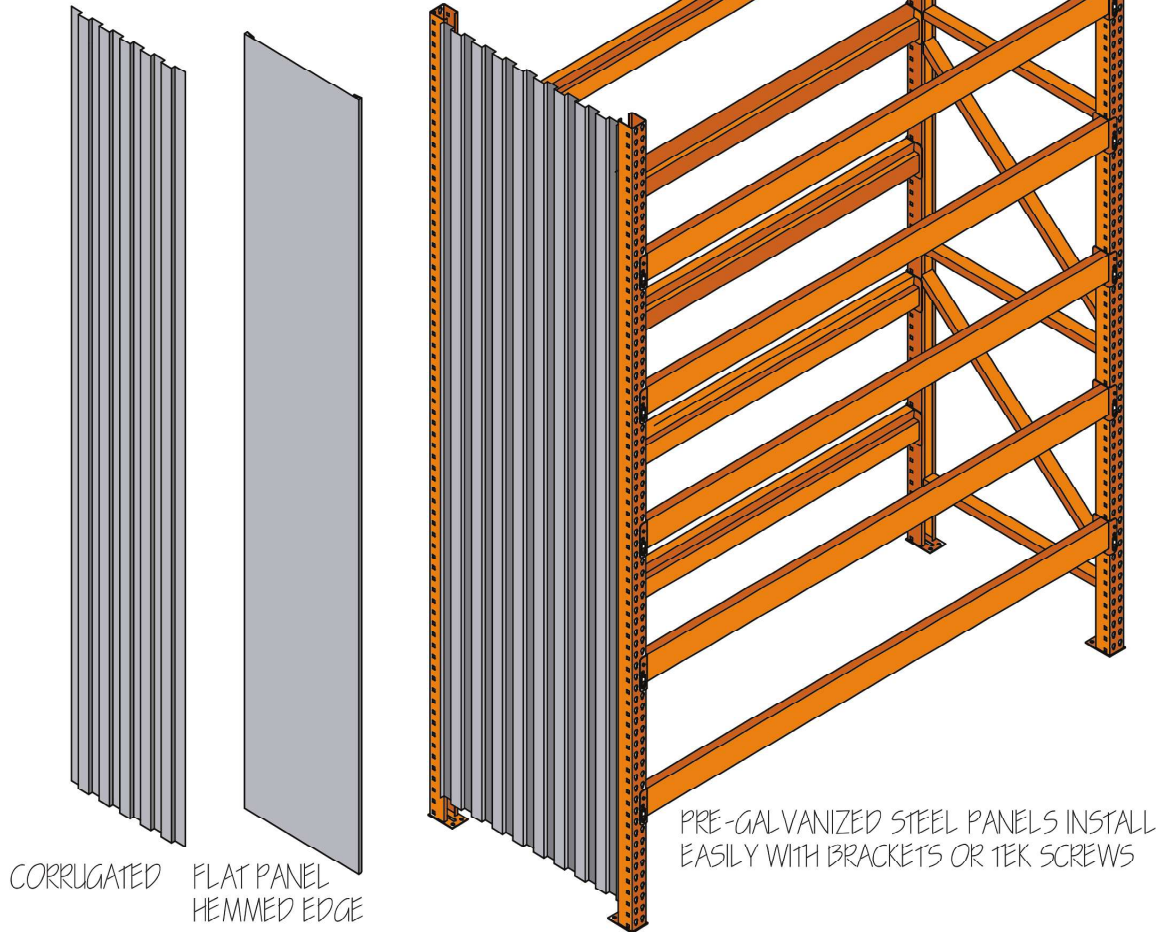

WOOD SPACER STRIPS

INSERT INTO STEP OF BEAM TO KEEP WOOD STICKERS SEPARATED FOR FIRE SAFETY & WATER FLOW

PRE-GALVANIZED MATERIAL

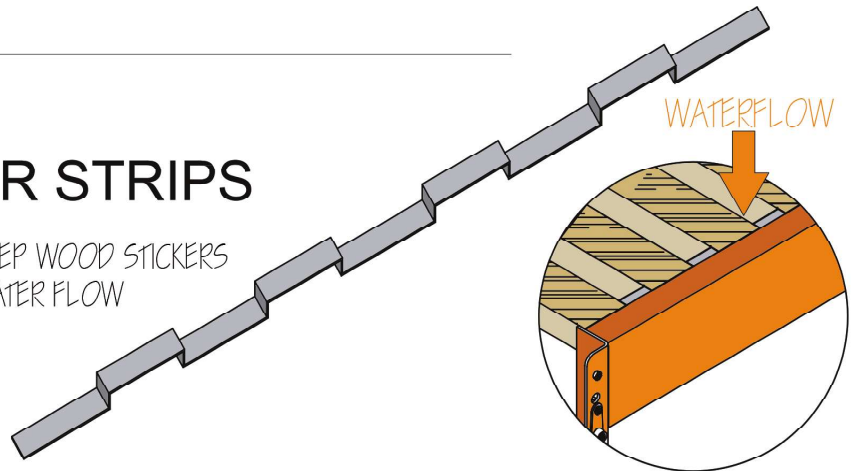

PRODUCT RETAINER OPTIONS

DOOR & WINDOW DISPLAY RETAINER BEAM

KEEP PRODUCT VERTICAL WITH RETAINER BEAMS
AT FRONT AND BACK OF BAY

PERFECT FOR LARGE STOCK WHICH SPANS
MULTIPLE BAYS

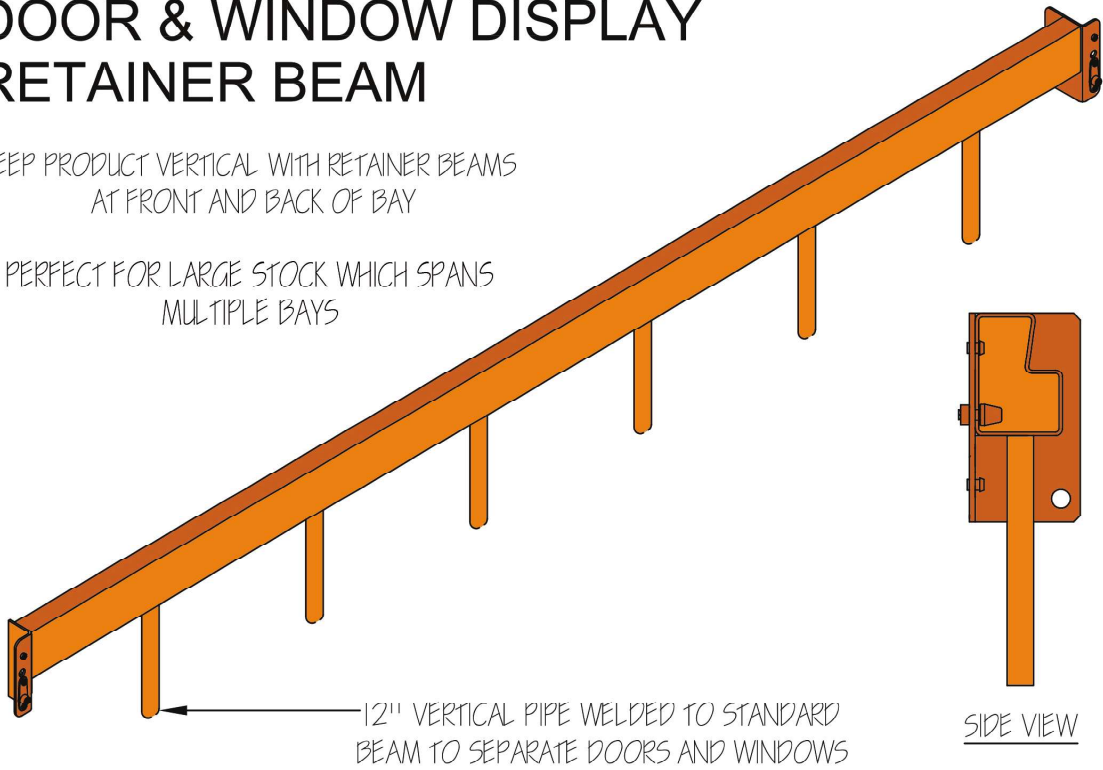

RETAINER BRACKETS

FIXED BRACKET WITH
REMOVABLE PIPE - AISLE DISPLAY

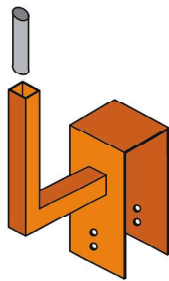

CHAIN MOUNTED REMOVABLE
PIPE - FLUSH TO BAY

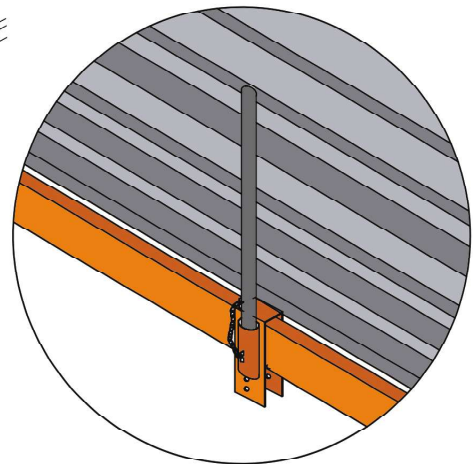
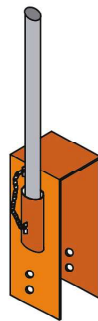

PERFECT FOR FENCE POSTS, CONDUIT OR PIPE

LARGE ITEM DISPLAY

BOARD RACK

SPECIAL FRAMES WITH ANGLED DESIGN PROVIDE CUSTOMER VISIBILITY & EASY ACCESS

SHORT FRONT POST DESIGN ALLOWS FOR HORIZONTAL STORAGE OF SHEET GOODS BELOW

12' POST HEIGHT AT REAR ALLOWS FOR PLACEMENT OF REAR BEAMS FOR ALL LENGTH BOARDS

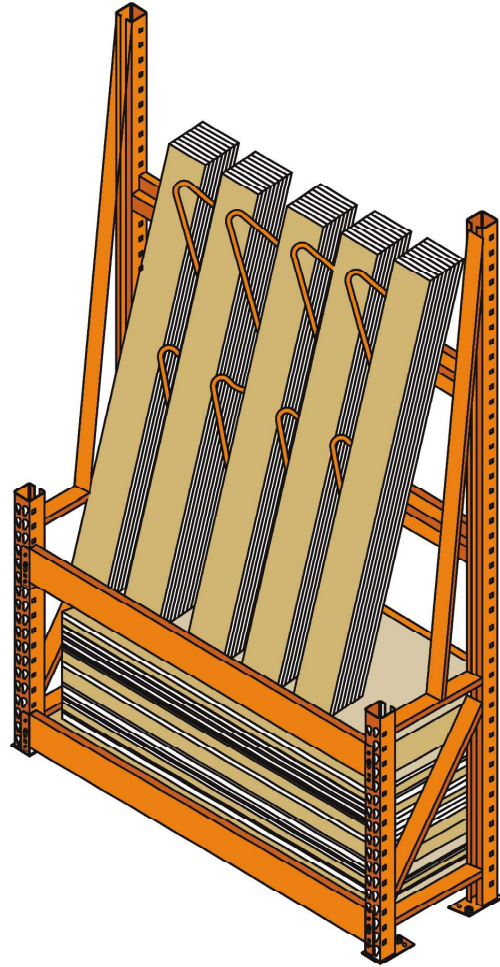

WIRE REEL HOLDERS

STORE FULL SPOOLS WITH COMPLETE ACCESSIBILITY

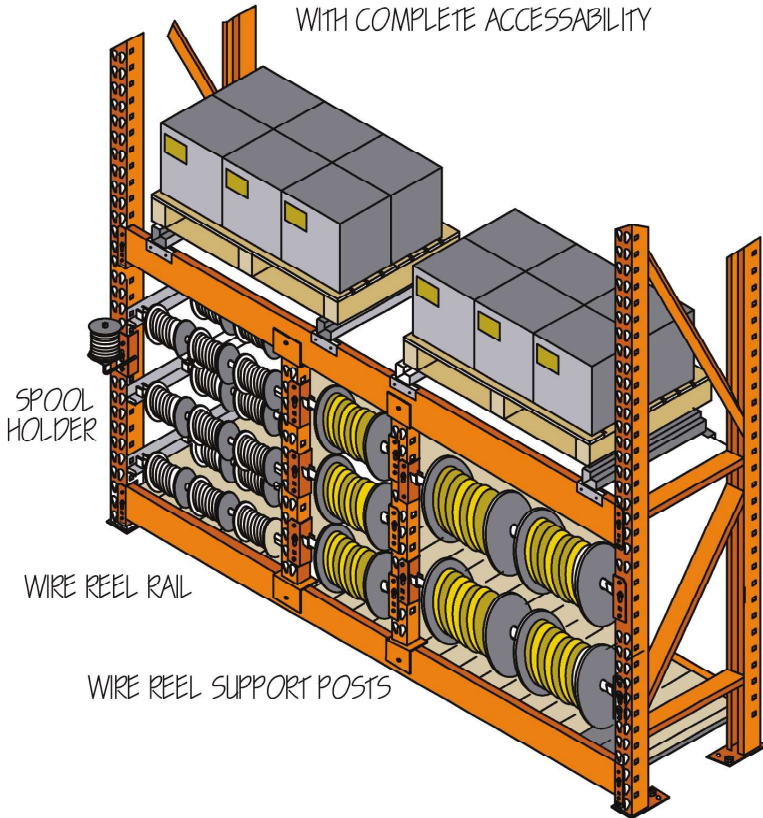

SPOOL HOLDER

MOUNTS TO POST FOR EASY CUSTOMER ACCESS

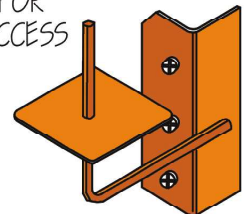

FAN RACK

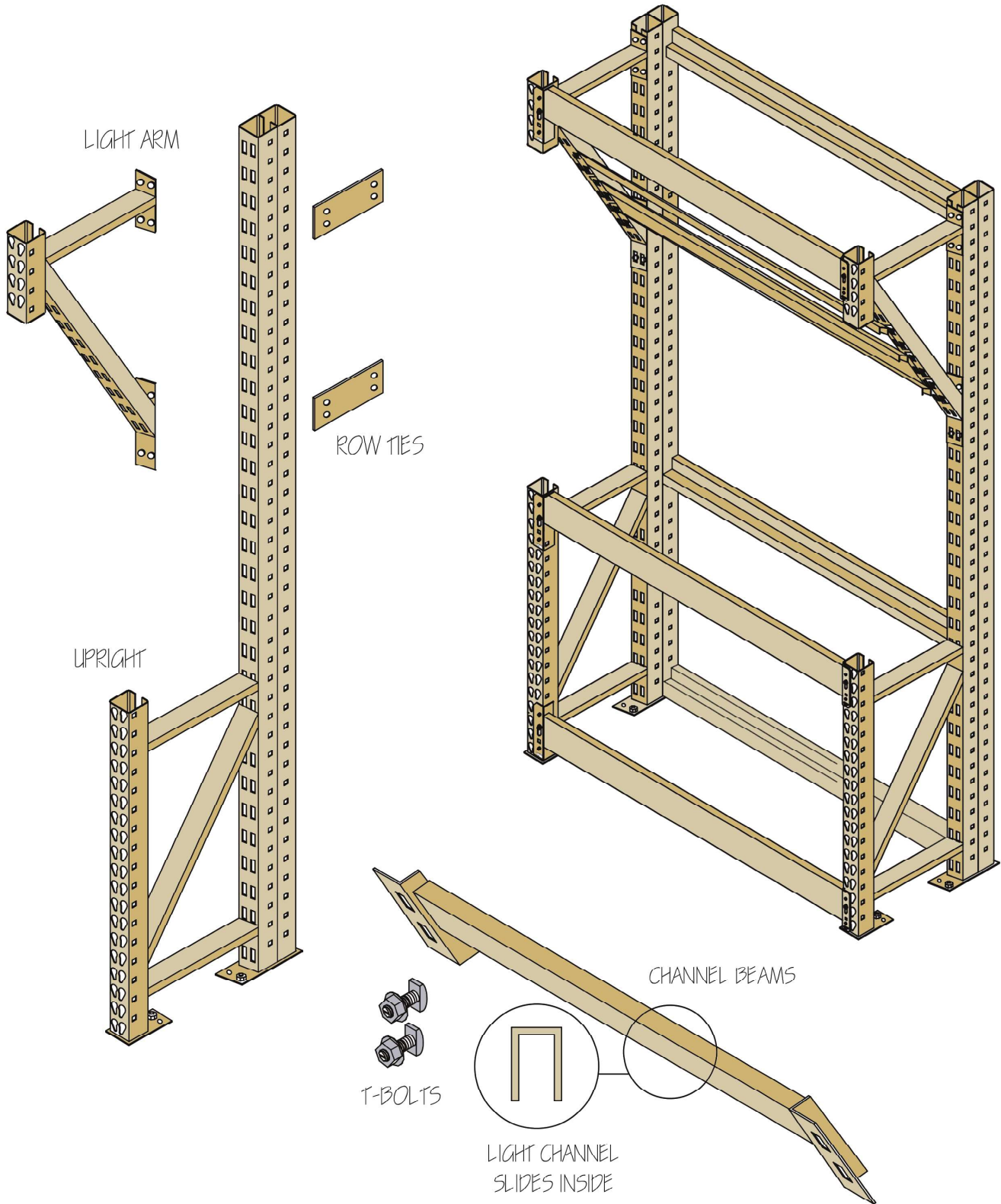

SPECIALTY DISPLAY

RUG TABLE

FOR DISPLAY OF RUGS AND OTHER MERCHANDISE

KIT INCLUDES:
UPRIGHTS
BEAMS
ROW SPACERS
HARDWARE
WOOD SUPPORTS

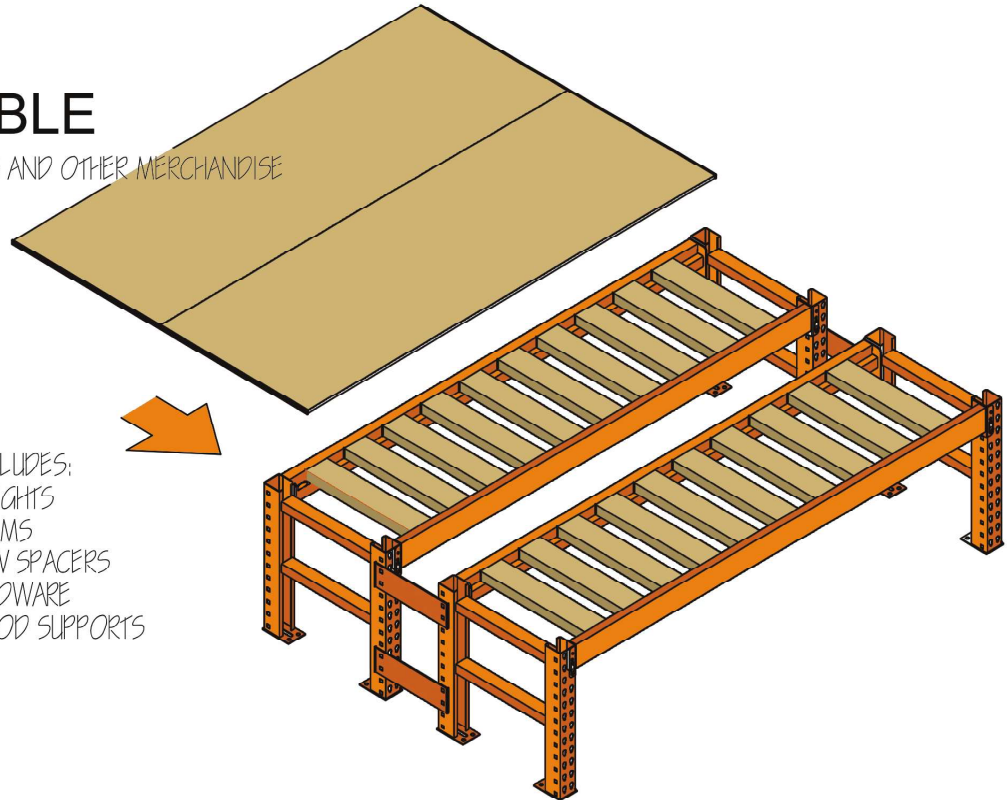

PALLET & BAGGED GOODS PROTECTION HOOK & SADDLE

PROTECT PRODUCT FROM CART & FORKLIFT DAMAGE

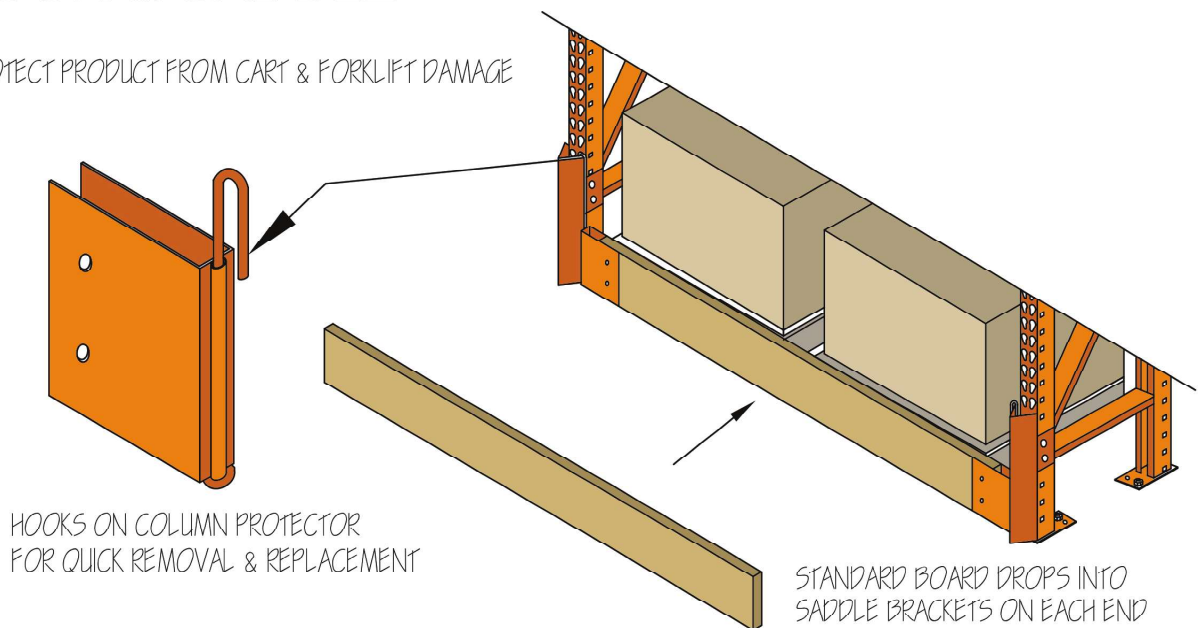

PEGBOARD SHELF

ULTRA THIN PROFILE SHELVING

MORE SHELF LEVELS = MORE PRODUCT = MORE SALES

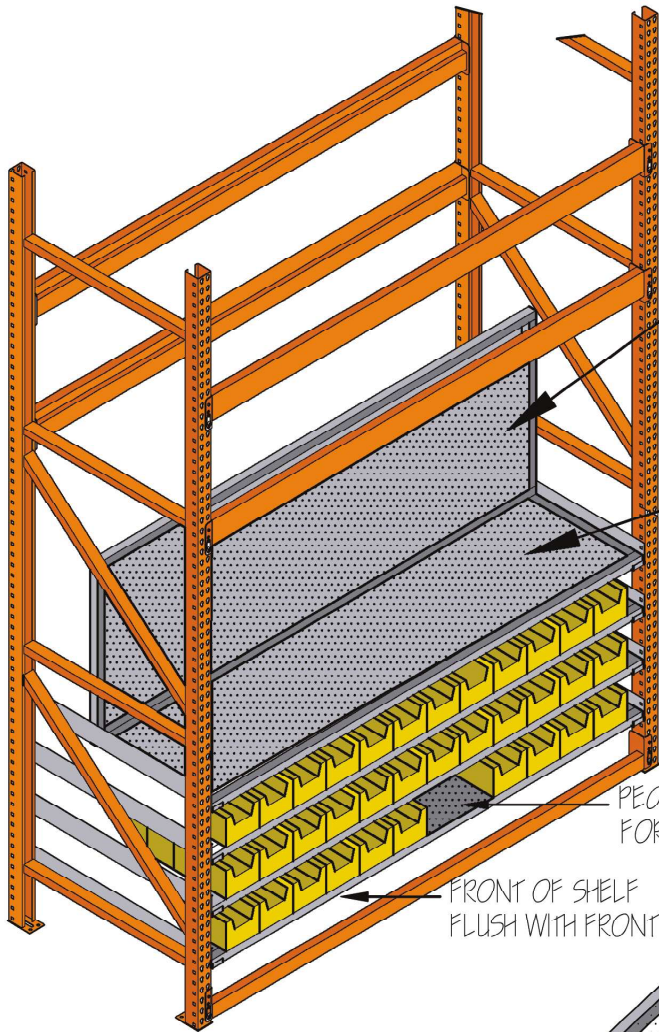

VERSATILE

STAND VERTICAL TO USE AS PEGBOARD SHELF

MULTI-USE

LAY FLAT TO USE AS PRODUCT SHELF

PEGBOARD ALLOWS WATER TO FLOW THROUGH FOR FIRE SAFETY

FRONT OF SHELF FLUSH WITH FRONT OF BAY

L-RAIL SHELF SUPPORTS

ADJUSTABLE SIDE RAIL
SUPPORT SHELVES
FOR 36" D - 48" D
RACKING

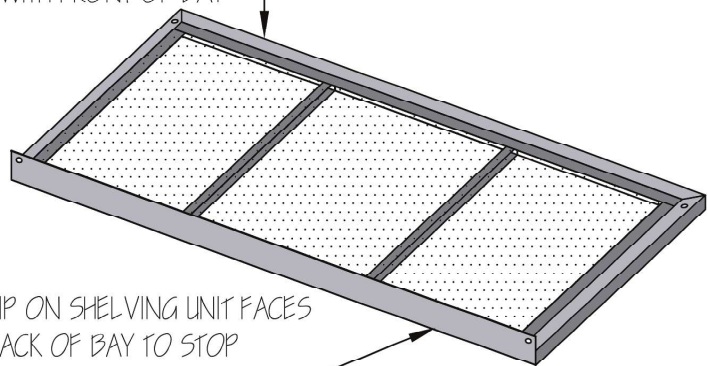
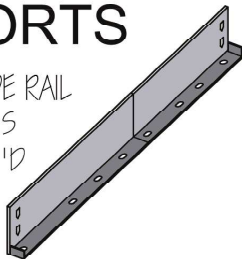

LIP ON SHELVING UNIT FACES
BACK OF BAY TO STOP
BOXES FROM FALLING BEHIND

PEGBOARD SHELF

GARDEN TABLE/SHELF

GARDEN TABLES

EASY SETUP - LAY
GARDEN TABLE ON
CEMENT BLOCKS

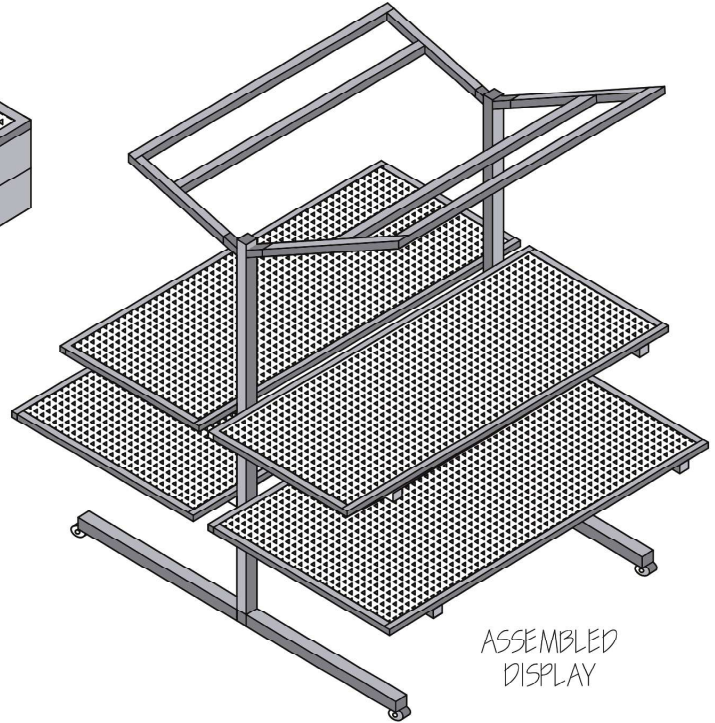
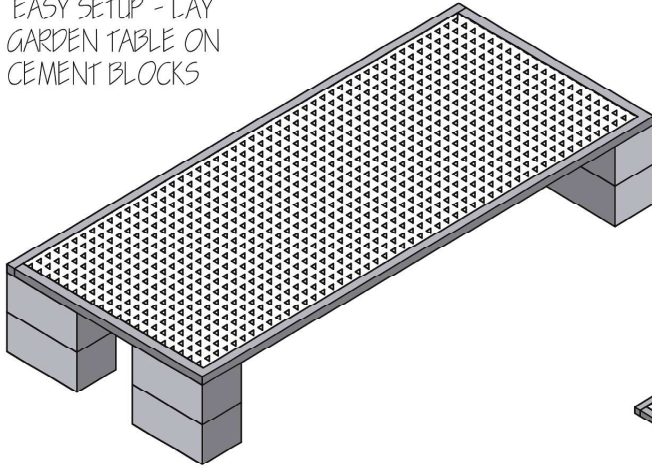

ASSEMBLED
DISPLAY

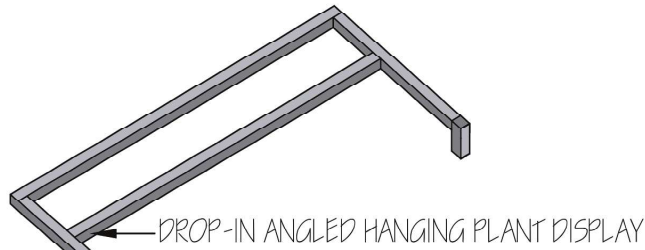

DROP-IN ANGLED HANGING PLANT DISPLAY

GARDEN CENTER PLANT DISPLAYS

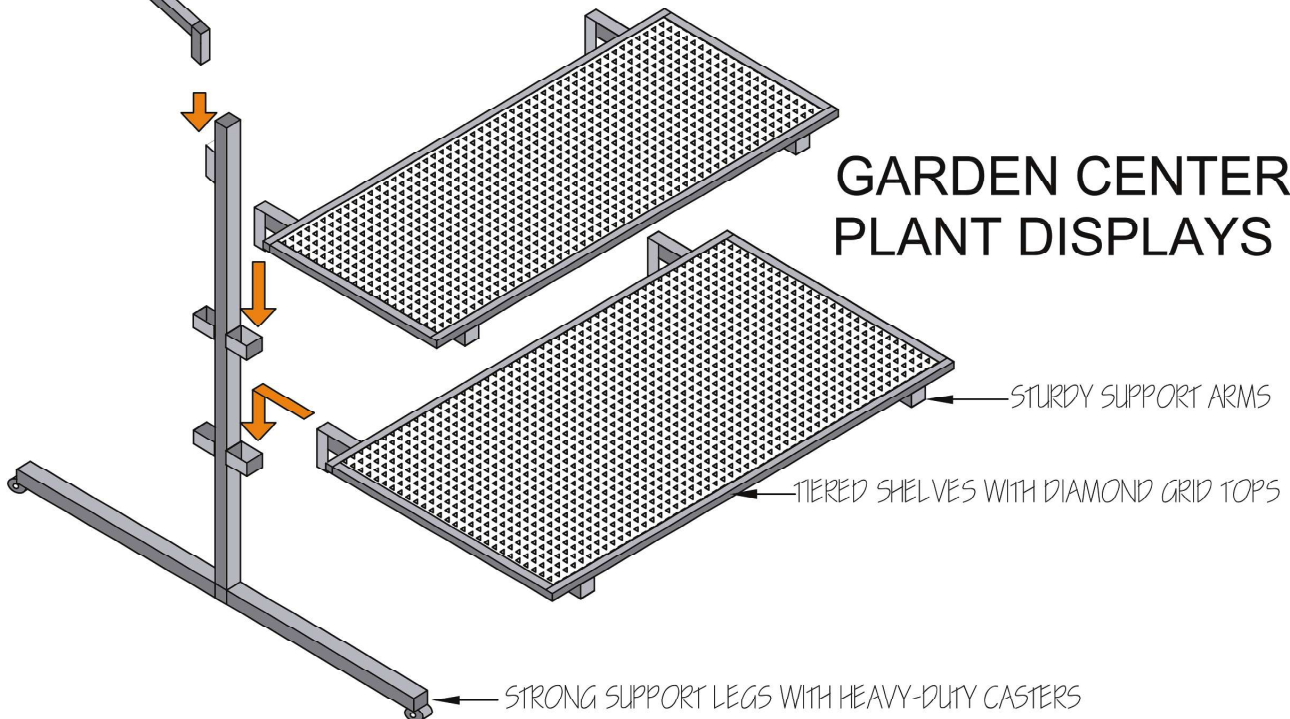

STURDY SUPPORT ARMS

TIERED SHELVES WITH DIAMOND GRID TOPS

STRONG SUPPORT LEGS WITH HEAVY-DUTY CASTERS

MOBILE PRODUCT IDEAS

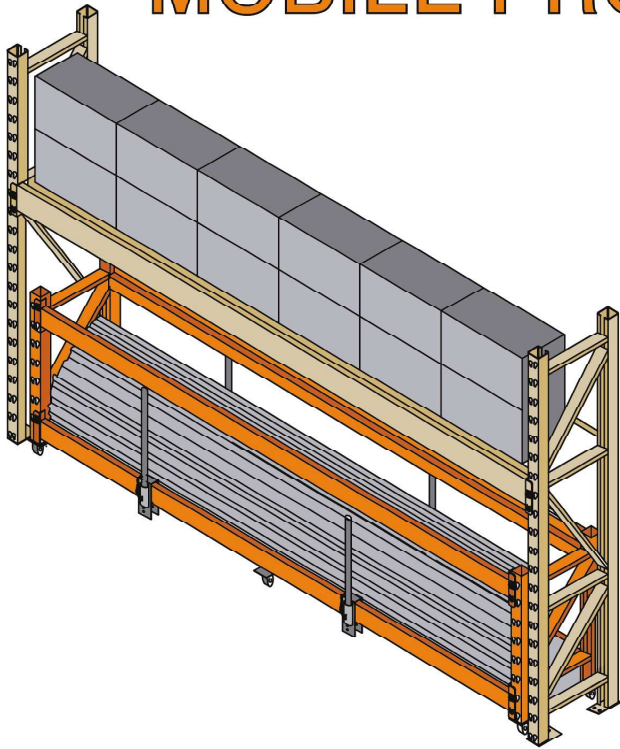

CONDUIT CART

ASSEMBLE IN STORE WITH BEAMS

HEAVY DUTY CASTERS INCLUDED

ROLLS UNDER RACK FOR EASY LOADING/ UNLOADING

BOLT-ON RETAINER POLES SECURE PRODUCT

GRAVITY FLOW RACK

ASSEMBLE IN STORE WITH STANDARD BEAMS OR SLANT FACE ANGLED BEAMS FOR LABEL VISIBILITY

DROP-IN TRACKS LET PRODUCT FLOW FORWARD TO PICKING POSITION

ALUMINUM ROLLER WHEELS FOR CONTINUOUS FLOW

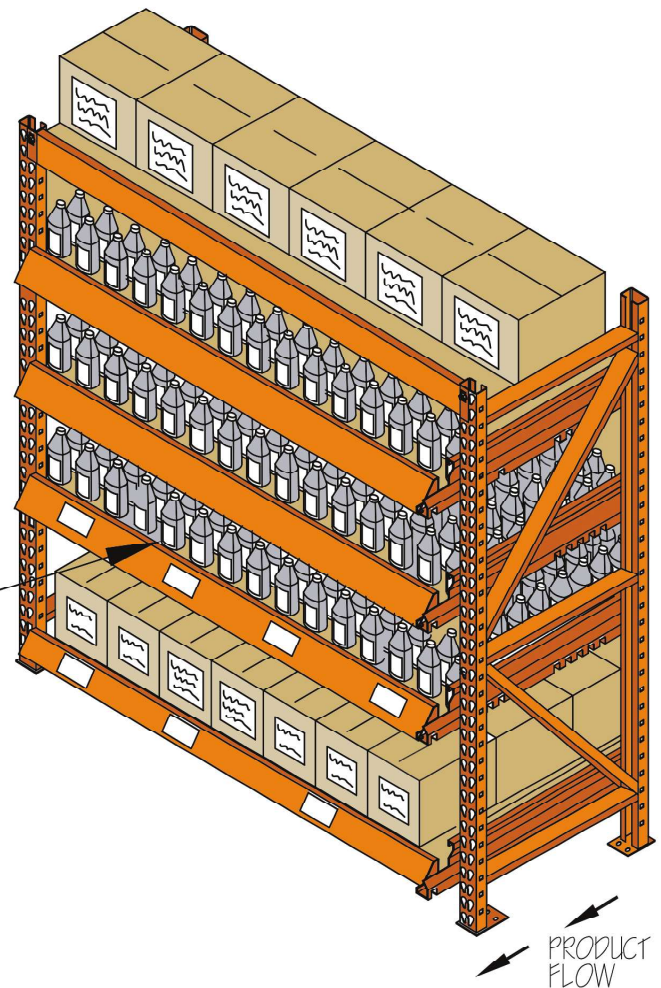
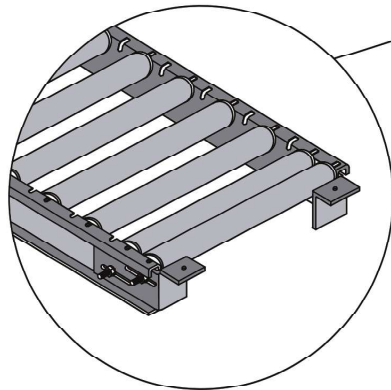

DIY TV MOUNT & DOORS

IN-RACK DOORS

ADD HIDDEN STORAGE TO YOUR RACKING SYSTEM WITH EASY MOUNT DOORS

RACK MOUNT TV

ADD TV DISPLAY TO RACKING WITH SPECIALTY MOUNTED BRACKETS

MOUNT LED TV VERTICALLY OR HORIZONTALLY
TV SITS FLUSH WITH FACE OF RACK

IN-BAY SWINGING DOOR WITH HEAVY-DUTY CASTERS

MAGNETIC CLOSING DEVICE

EASY MOUNT HINGES LOCK INTO RACK

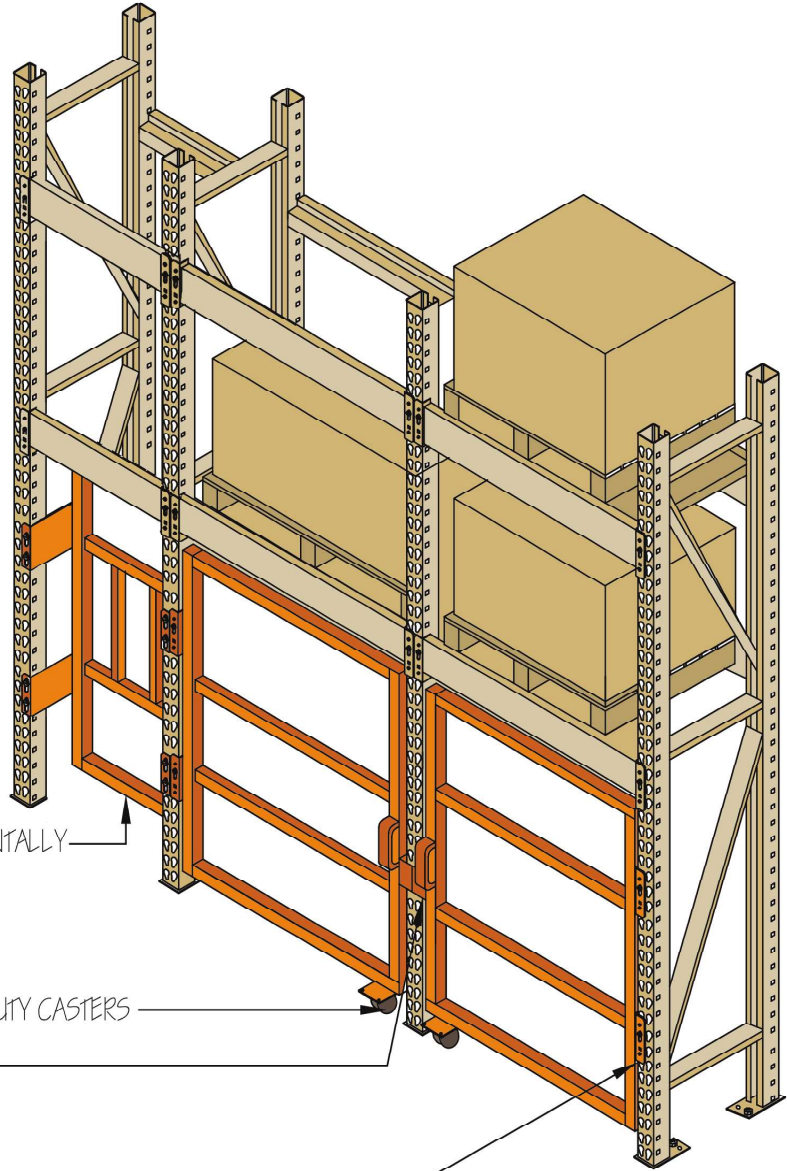

ENDCAP SHELF

CANTILEVERED DISPLAY
THINK BIG SHELVES

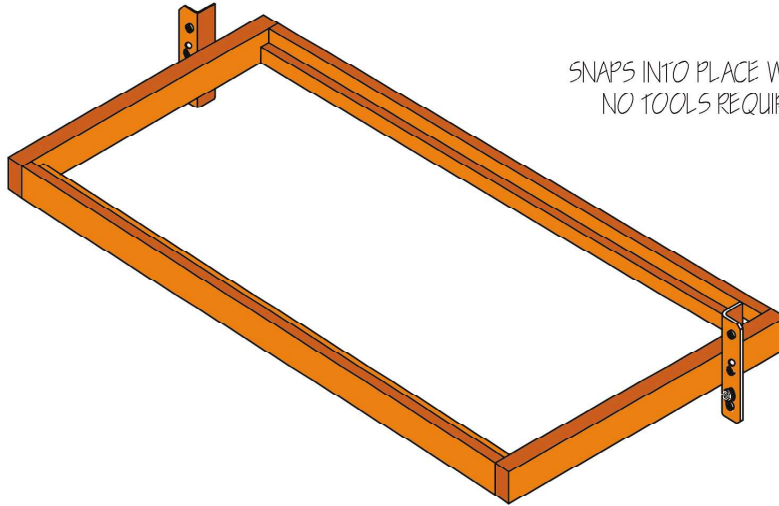

SNAPS INTO PLACE WITH
NO TOOLS REQUIRED

ENDCAP DISPLAY
SHELF

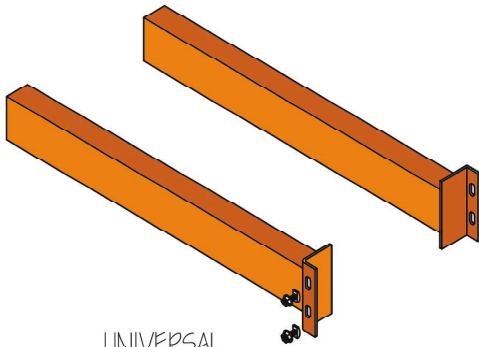

UNIVERSAL
ENDCAP ARM SHELVES

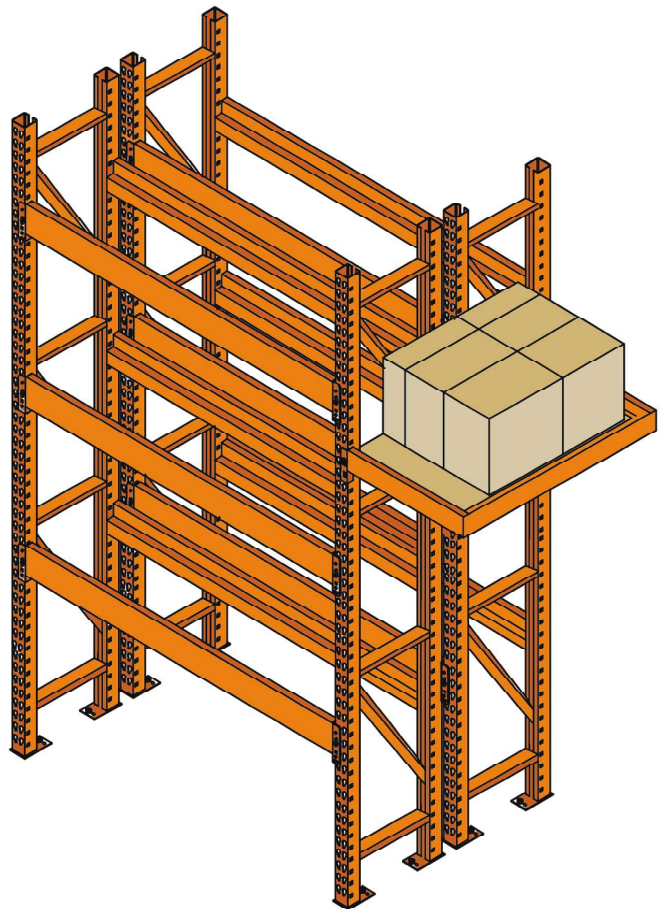

RACK REPAIR

BRACING ONLY REPAIR

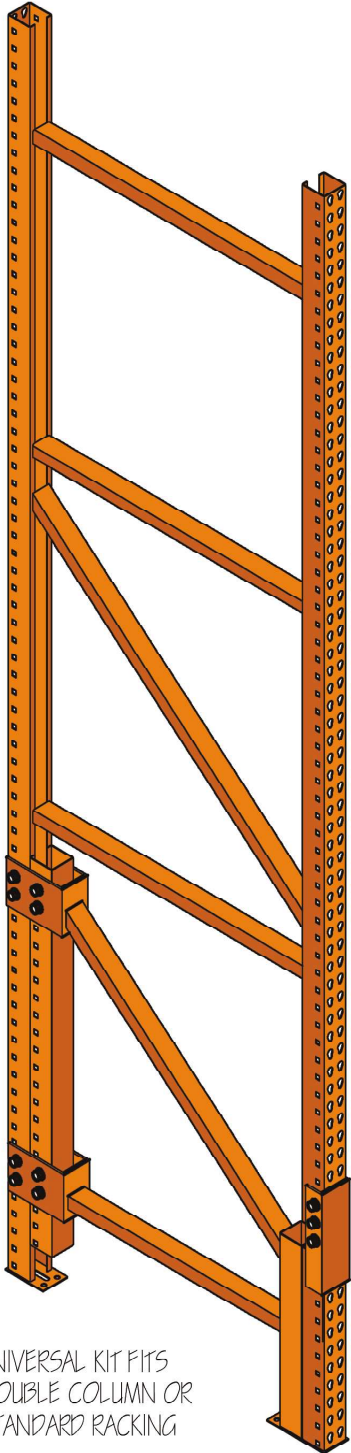

UNIVERSAL KIT FITS
DOUBLE COLUMN OR
STANDARD RACKING

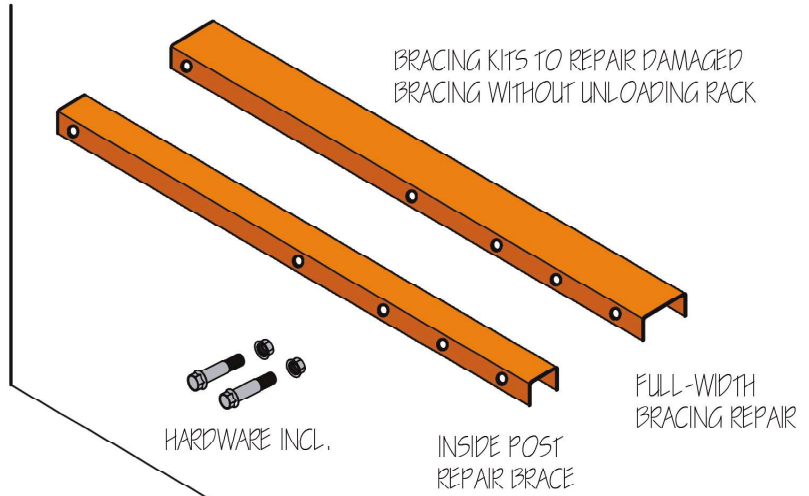

BRACING KITS TO REPAIR DAMAGED
BRACING WITHOUT UNLOADING RACK

HARDWARE INCL.

INSIDE POST
REPAIR BRACE

FULL-WIDTH
BRACING REPAIR

BOLTS TO FRONT &
REAR POSTS

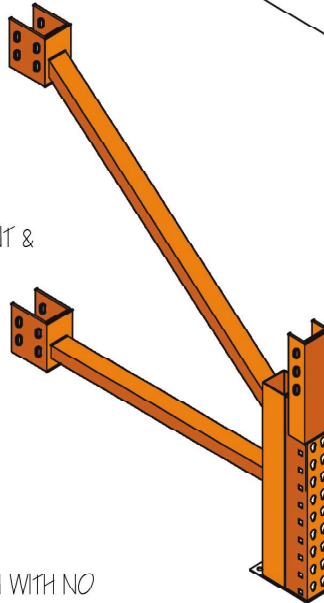

BOLTED DESIGN WITH NO
ON-SITE WELDING REQUIRED

WELDED CLIFF FOR FAST
& EASY INSTALLATION

LOW-LEVEL POST REPAIR KIT

RETAIL SIGNAGE

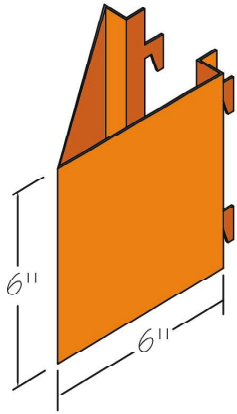

SMALL AISLE SIGN
SNAP-IN TABS FOR EASY INSTALLATION & RELOCATION

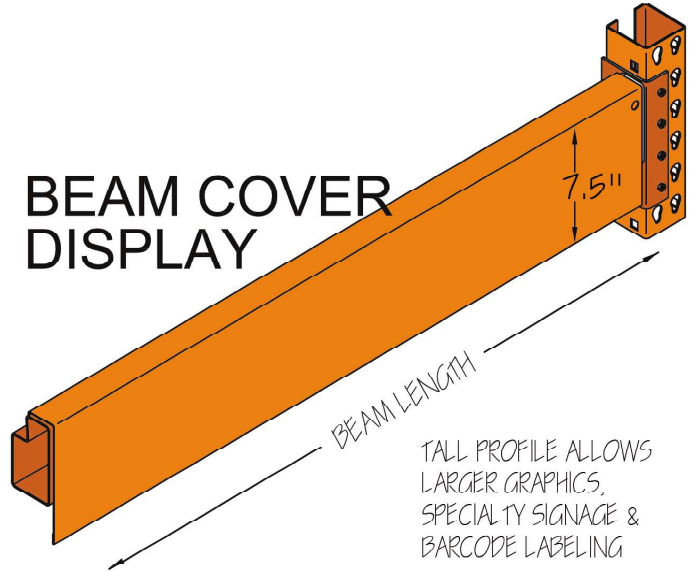

BEAM COVER DISPLAY

TALL PROFILE ALLOWS LARGER GRAPHICS, SPECIALTY SIGNAGE & BARCODE LABELING

JUNCTION BOX - RACK MOUNT

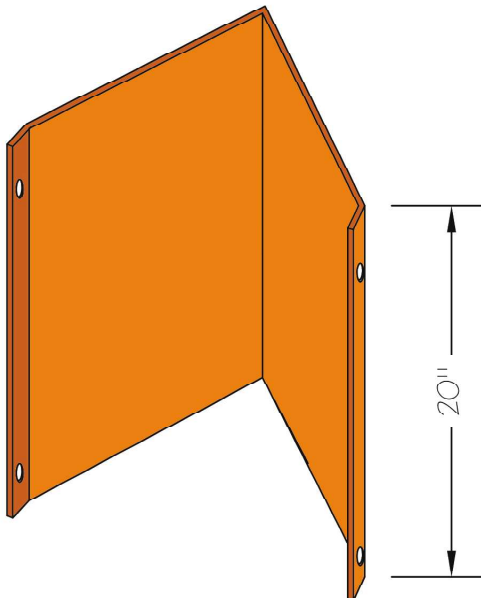
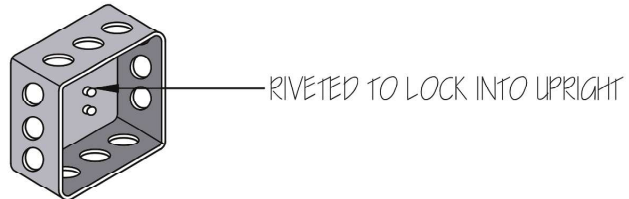
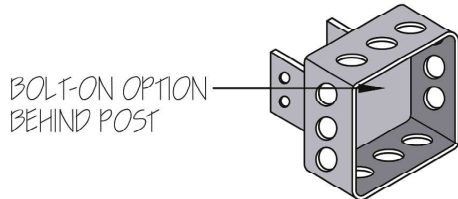

LARGE AISLE SIGN

RETAINER CABLE KEEPS SIGNAGE ATTACHED TO RACK WHEN HIT

BOLTS TO UPRIGHTS FOR AISLE IDENTIFICATION

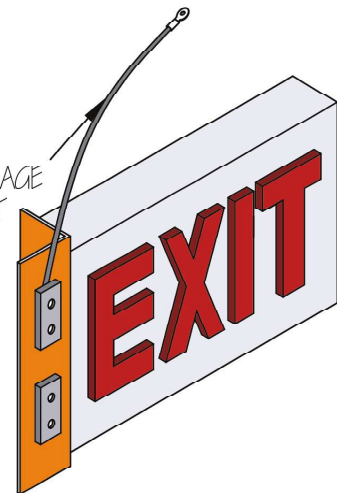

ULTRA-STRONG MAGNETIC MOUNT TO RACK

FALL-AWAY EXIT SIGN

RETAIL CAPABILITIES

ENGINEERING

SEISMIC CALCULATIONS

PERMITTING

STORE TAKEOFFS

INSTALLATION

SAFETY WALKS

RACK REPAIR

FIXTURE DESIGN

SEISMIC DESIGN

RACK INSPECTIONS

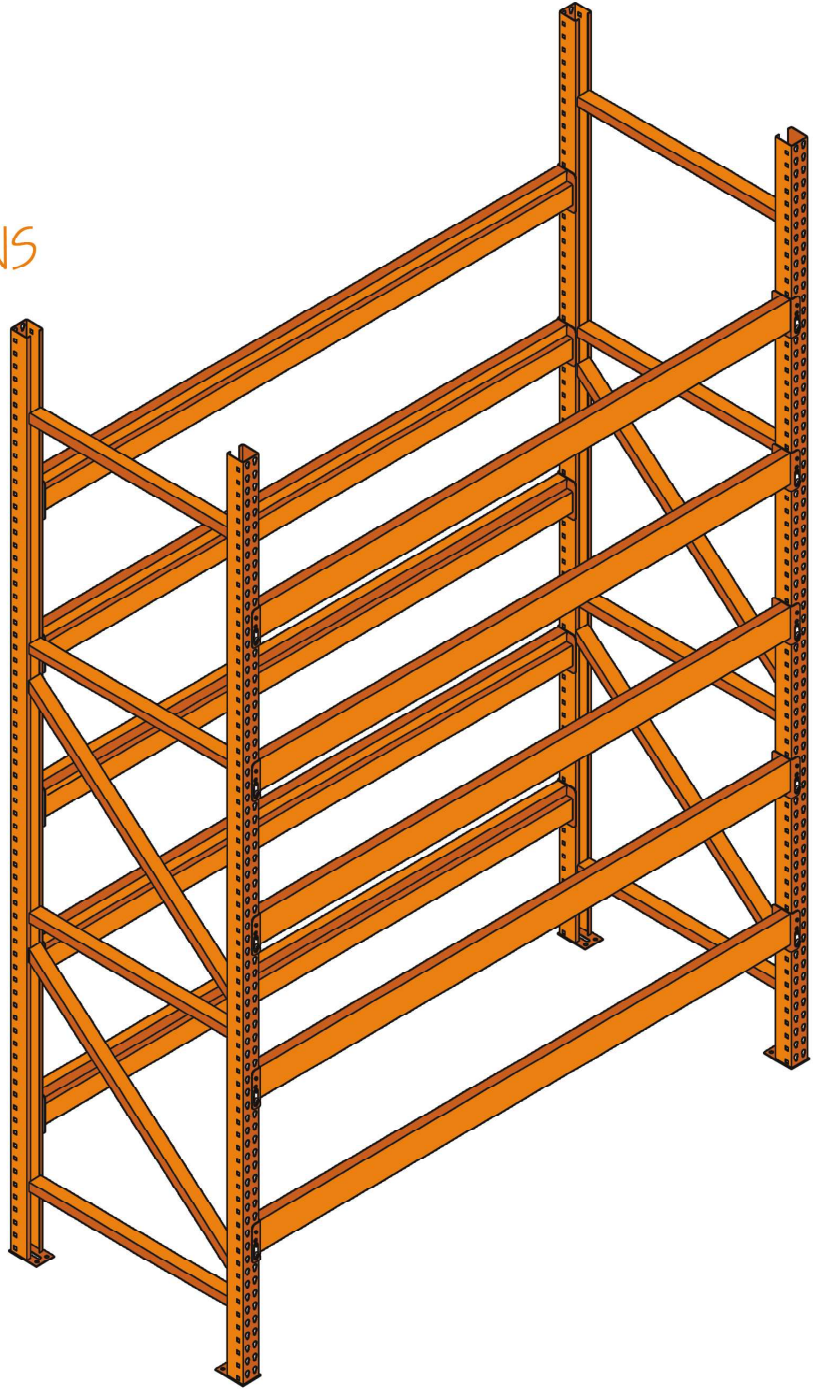

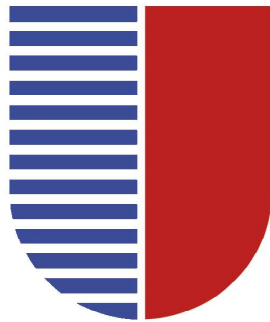

UNARCO
RETAIL

www.UNARCORACK.com

retail@unarcorack.com

1-800-775-6563

12/18